

HAPPY D-TYPE

LIFTING HEAVY
CARGO FOR
WORLDWIDE
TRANSPORT



GIANT
MARINE

BIG LIFT

HAPPY D-TYPE

NEWBUILDING HAPPY D-TYPE
 HAPPY DELTA, HAPPY DIAMOND, HAPPY DOVER, HAPPY DRAGON, HAPPY DYNAMIC

HATCH OPENINGS AND ALLOWABLE LOADS

HATCH OPENINGS

Weather deck	hold 1	25.6 x 17.8 m
	hold 2	70.4 x 17.8 m
Tween deck	Hold 1:	25.6 x 17.8 m
	Hold 2:	64.0 x 17.8 m

ALLOWABLE LOADS

Weather deck hatch covers	3.6 t/m
Tween deck hatch covers	5.5 t/m
Tank top	20.0 t/m ²

FLOOR SPACE

Weather deck		2,788 m ²
Tween deck	hold 1	1,456 m ²
	hold 2	1,253 m ²
Tank top	hold 1	398 m ²
	hold 2	1,090 m ²

CRANES

2 x 400 mt + 1 x 120 mt

COMBINABLE

800 mt

TROLLEY

50 mt SWL

PRINCIPAL DIMENSIONS

Length overall	156.93 m
Breadth moulded	25.60 m
Height in hold	13.25 m
Summer draft	10.32 m

REGISTRATION

The Netherlands

CLASS

Lloyds Register X100A1, Iceclass 1A (Finnish-Swedish Ice class rules), Strengthened for heavy cargoes, LA, LI, NAV1, *IWS, XLMC, UMS, with descriptive notes: PCWBT, BWMP, SCM

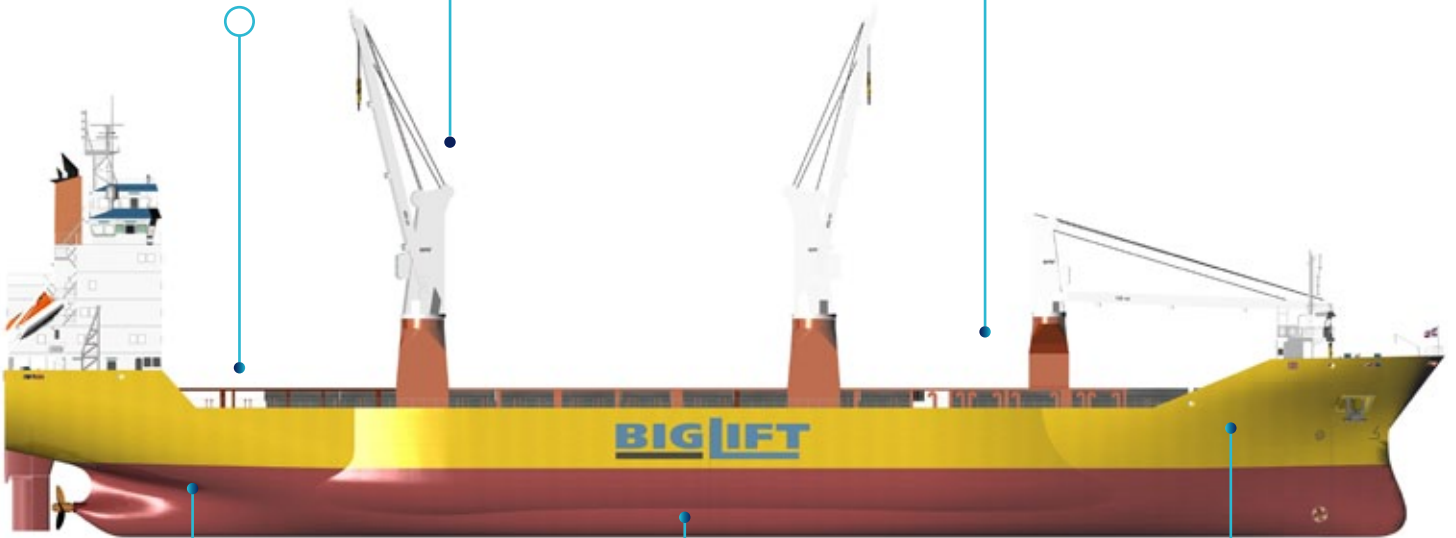

MAIN ENGINE

Wärtsilä	8400 kW
Bowthruster	850 kW
Service speed	17 kn at draft 7 m

CAPACITY

Grain = bale	20,892 m ³
If tween deck installed	19,192 m ³

DEADWEIGHT

At Summer (sea water) draft
 17,518 mton inc. tween deck hatch covers, pillars

HAPPY D-TYPE

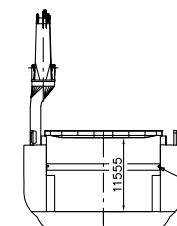
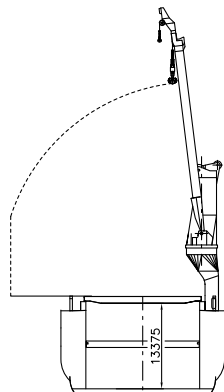
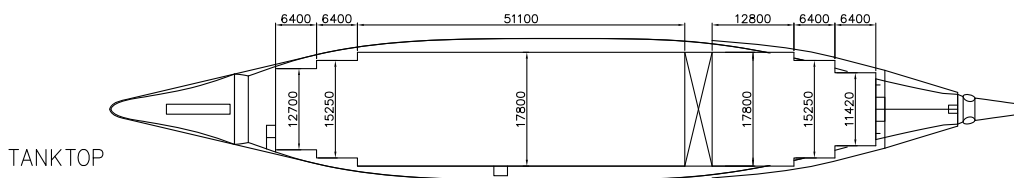
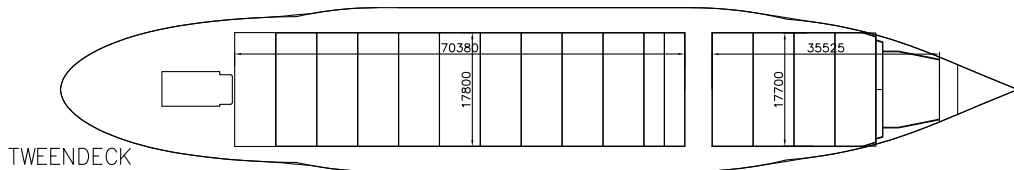
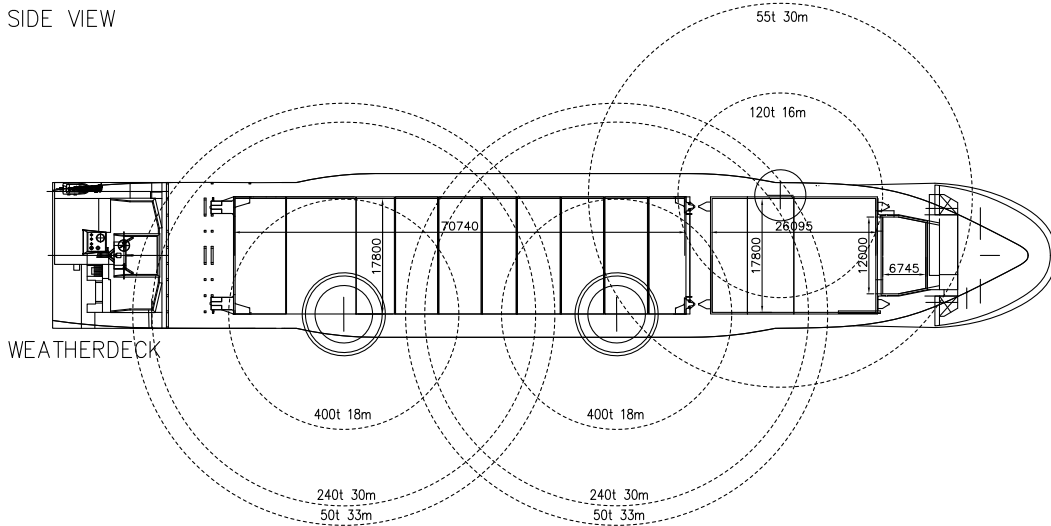
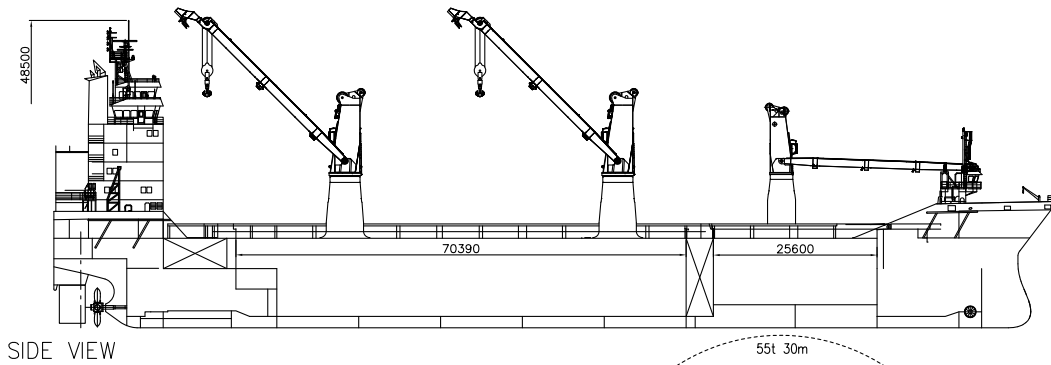

Tweendeck hatches adjustable in height

Vessel TC description - m.v. HAPPY DRAGON

General				
type of vessel	Multi-purpose – Heavy cargo vessel			
class	Lloyds Register \boxtimes 100 A1, Strengthened for Heavy Cargoes, Containers in Holds and on Weather deck Hatch Covers, Timber Deck Cargoes, *IWS, LI, Ice Class 1A FS, Weather deck hatch covers in No 2. Cargo hold may be omitted up to a maximum draught of 7.5 m, \boxtimes LMC, UMS, NAV1, descriptive notes: ShipRight (SCM), BWMP(S), PCWBT, tanktop suitable for regular discharge by grabs with a maximum unladen weight of 18 tonnes			
built	2011			
flag	Dutch			
port of registry	Amsterdam			
owner	C.V. Scheepvaartonderneming Happy Dragon			
P&I club	Standard Steamship Owners' P&I Bermuda			
official number	23071 Z 2011			
IMO no.	9551961			
NSI No.	53220			
call sign	PBXI			
satellite number	phone	+870 7731 57904		
	GSM	+31 6 2380 1346		
	fax	+31 20 4489 146		
	SAT-C telex	4246 66 110 / 111		
	e-mail	pbxi@globeemail.com		
Tonnage		<u>International</u>	<u>Panama</u>	<u>Suez</u>
GT	13,950			
NT			
Measurements				
Length overall	156.93 m			
Length between perpendiculars	147.75 m			
Breadth overall	25.60 m			
Depth moulded	13.972 m			
Draft Summer (salt)	10.351 m			
Deadweight Summer (salt)	18,163 mton exc TWC, 17,518 inc. TWC			
Airdraft over keel	47.40 m			
Immersion (min, 5m draft)	27.00 mton / cm			
(max, 9m draft)	31.00 mton / cm			
Floor space weather deck	1788 m ² (deck space only)			
tween deck	Hold 1: 456 m ² Hold 2: 1253 m ²			
lower hold	Hold 1: 398 m ² Hold 2: 1090 m ²			

<p>Cargo capacity hold 0 hold 1 hold 2</p>	<p>600 m³ 5032 m³ (in case tweendeck installed, 400 m³ less) 15860 m³ (in case tweendeck installed, 1253 m³ less)</p>
<p>Hatches Weather deck hatch no. 0 hatch no. 1 hatch no. 2 Tween deck hatch no. 1 hatch no. 2 Bulkheads / compartments hold heights: hatch 1 hatch 2 low position: middle position high position Total height, no tween decks installed: Deck strength weather deck tween deck fixed tweendeck + monkey rocks tank top</p>	<p>6.740 x 12.000 25.596 x 17.800 m 70.389 x 17.800 m steel lift away, end folding type and rolling type 25.596 x 17.800 m (4 steel pontoons 6.37 x 17.72 m) 63.999 x 17.800 m (11 steel pontoons: 2 of 3.17 x 17.70 m, 13 of 6.37 x 17.7 m) removable pontoons for up to 12 compartments lower hold tween deck 6.4831m 4.075 m 3.027 m 9.105 m 6.480 m 5.895 m 9.620 m 2.755 m hatch 1: 11.555 m, hatch 2: 13.375 m 2.6 mton/m² 3/6 mton/m² panels 3-7 of hold 2 5.5 mton/m² 12.0 mton/m² 20.0 mton/m²</p>
<p>Cargo facilities Cranes position No. 1 crane on PS No. 2 and 3 cranes on SB Cranes 2 and 3 working in tandem: auxiliary hoist cranes 2 and 3</p>	<p>120 mton SWL 16m, 90mt - 21m, 55mt - 30m 400 mton SWL at 6 – 18 m radius or 325 mton SWL at 6 – 22 m radius or 200 mton SWL at 4.5 – 30 m radius or 240 mton SWL at 5 – 30 m radius max 800 mton SWL (subject to cargo details) (basis list = 0) 50 mton SWL at 6.5 – 33 m radius</p>

Lifting beams capacity / length	2 units, SWL 440 mton, length 12 m between outer lifting points. Own weight per beam 16 mton
Mechanical details mechanical ventilation, empty holds CO ₂ evaporator power supply reefer plugs	hatch 0: 11x per hour hatch 1: 20x per hour hatch 2: 15x per hour yes yes; capacity 20t/day 440 volts, 60 Hz up to 1275 kW, 60 pcs
Tank capacities ballast fresh water IFO MDO	7,675.00 m ³ 200.00 m ³ 1,500.00 m ³ 310.00 m ³
Speed/Consumption Speed through water with fuel consumption basis IFO 380 centistokes; wind not exceeding 2 beaufort; calm smooth sea without current; deep water; draft 7 m, 17.0 knots, draft 8 m	
Fuel consumption per day (even keel) In port:	abt. 25 mt IFO 380 cSt at 14.5 kn abt. 30 mt IFO 380 cSt at 15.5 kn abt. 37 mt IFO 380 cSt at 16.0 kn no MDO at sea, except for manoeuvring abt. 3.8 ton MDO per day, cargo gear working abt. 1.7 ton MDO per day, cargo gear idle
Engine type bow thruster capacity ballast pumps, capacity ballast Intering system	Wärtsilä 8400 kW engine Bowthruster 850 kW 2 pumps, each approx. 500 m ³ /hr 4 tanks total 436 m ³ max. ballasting 200 m ³ in 3 minutes
Cargo space tween deck hatch 1 open tween deck hatch 1 closed container capacity deck hold (upto IMO line) (basis 20 ton / teu, 30 ton / feu)	22,775.90 m ³ , hatch 2 NOT installed 21,606.40 m ³ , hatch 2 in low position 21,624.90 m ³ , hatch 2 in middle / high position <u>TEU</u> <u>FEU</u> + 45' + <u>TEU</u> 630 145 + 92 + 156 <u>461</u> <u>215</u> + <u>31</u> <u>1091</u> <u>360</u> + <u>92</u> + <u>187</u>

stackloads	deck tween deck hold	52 ton/stack TEU, 60 ton/stack FEU 48 ton/stack TEU, 52 ton/stack FEU 125 ton/stack TEU, 175 ton/stack FEU
Remarks: Vessel is fully equipped Vessels is fully self-sustained.		

All details are approximate and without guarantee. They must not be used as basis for charter parties or contracts without owner's explicit written authority.

GIANT MARINE

General Agents for BigLift Shipping B.V
3 rue du Maréchal de Lattre de Tassigny
78150 LE CHESNAY
Tel: 01.39.63.37.37
Fax: 01.39.55.81.49
Email: info@giantmarine.com

Mic: **M. Gilles THOMAS**
Email: thomas@giantmarine.com

Mic: **M. Paul-Henri TANON**
Email: tanon@giantmarine.com