

HAPPY S-TYPE

LIFTING HEAVY
CARGO FOR
WORLDWIDE
TRANSPORT



GIANT
MARINE

BIGLIFT

HAPPY S-TYPE

HAPPY SKY, HAPPY STAR

HATCH OPENINGS AND ALLOWABLE LOADS

HATCH OPENINGS

Weather deck	96 x 17.7 m
Tween deck	92 x 17.7 m

ALLOWABLE LOADS

Weather deck hatch covers	12.5 t/m ²
Tween deck hatch covers	12.5 t/m ²
Tank top	20.0 t/m ²

FLOOR SPACE

Weather deck	1,630 m ²
Tween deck	1,742 m ²
Tank top	1,530 m ²

CRANES

2 x 900 mt SWL

COMBINABLE
1800 mt

TROLLEY
37.5 mt SWL

PRINCIPAL DIMENSIONS

Length overall	154.80 m
Length p.p.	145.80 m
Breadth moulded	26.50 m
Scantling draft	9.50 m
Draft open sailing	7.50 m

REGISTRATION

The Netherlands

CLASS

LRS X100 A1, Ice class 1A (Finnish) strengthened for heavy cargoes

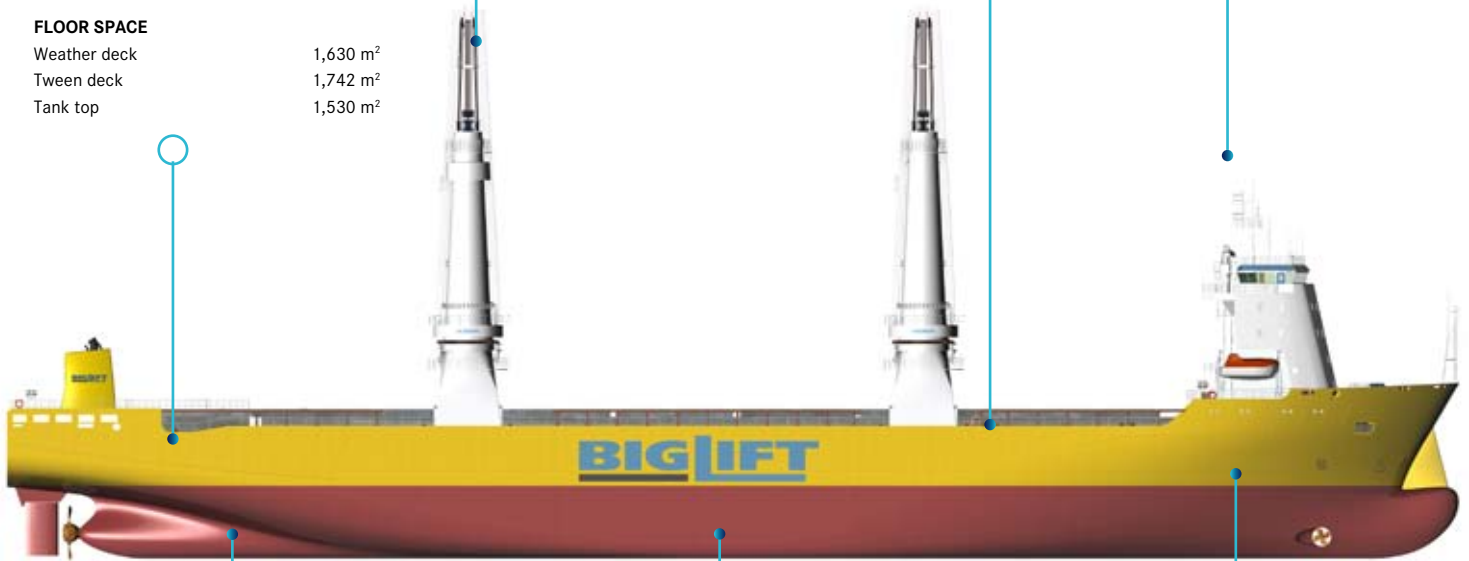

MAIN ENGINE

Wärtsilä	8775 kW
Bowthruster	1000 kW
Service speed	17 kn

CAPACITY

Grain = bale	20,561 m ³
If tween deck installed	17,068 m ³

DEADWEIGHT

At Scantling draft 18,680 mton inc. tween deck hatch covers, pillars

Vessel TC description - m.v. HAPPY S Type

Both vessels HAPPY SKY and HAPPY STAR are presently under construction for delivery in 2012, therefore only a preliminary short description is available here after.

All details are approximate and without guarantee. They must not be used as basis for charter parties or contracts without owner's explicit written authority.

GIANT MARINE

General Agents for BigLift Shipping B.V
3 rue du Maréchal de Lattre de Tassigny
78150 LE CHESNAY
Tel: 01.39.63.37.37
Fax: 01.39.55.81.49
Email: info@giantmarine.com

Mic: **M. Gilles THOMAS**
Email: thomas@giantmarine.com

Mic: **M. Paul-Henri TANON**
Email: tanon@giantmarine.com

HAPPY S-TYPE

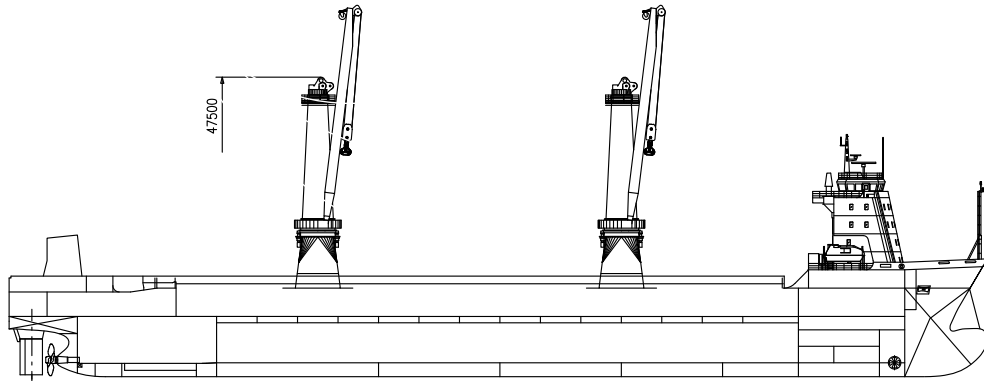

SIDEVIEW

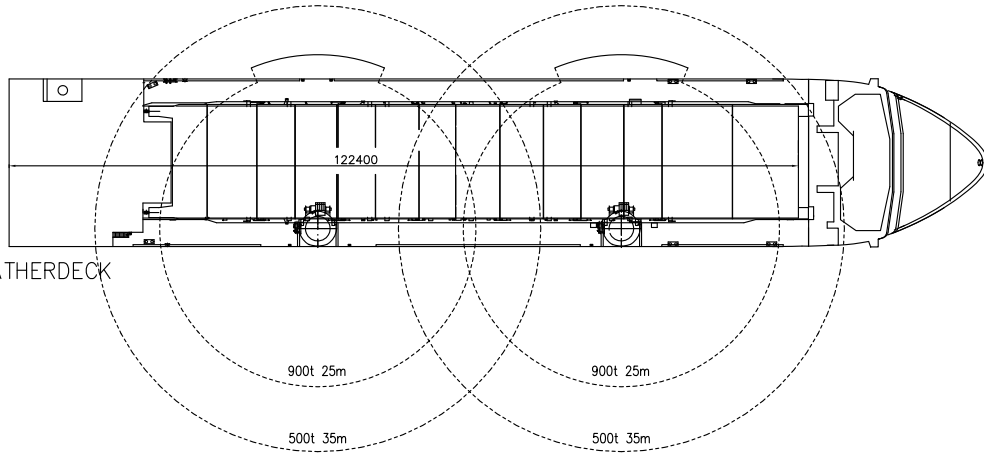

WEATHERDECK

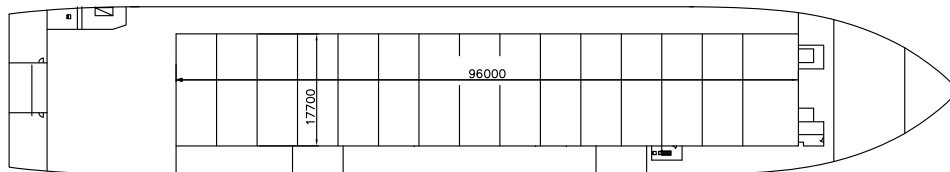

TWEENDECK

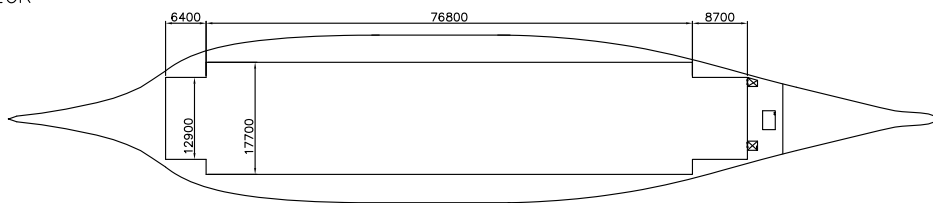

TANKTOP

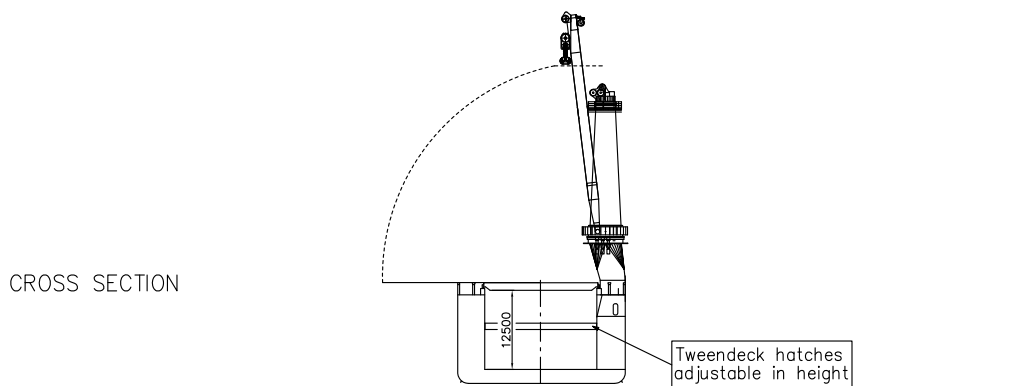

CROSS SECTION

HAPPY S-TYPE

CLASS				LRS X100 A1, Ice class 1A (Finnish) strengthened for heavy cargoes
Principal Dimensions	Length overall	154.80	m	
	Length p.p.	145.80	m	
	Breadth moulded	26.50	m	
	Scantling draft	9.50	m	
	Draft "open sailing"	7.50	m	
Deadweight	Scantling	18,680	mton	inc. tween deck hatch covers, pillars
Capacity	Grain = bale	20,561	m ³	if tweendeck installed, 17.068 m3
Floor space	Weather deck	1,630	m ²	
	Tween deck	1,742	m ²	
	Tank top	1,530	m ²	
Hatch openings	Weather deck	96 x 17.7	m	
	Tween deck	92 x 17.7	m	
Hatch heights	total	12.500	m	adjustable tween decks
Allowable loads	Weather deck hatch covers	4.0	t/m ²	
	with pillars	12.5	t/m ²	
	Tween deck hatch covers	4.0	t/m ²	
	with pillars	12.5	t/m ²	
	Tank top	20.0	t/m ²	
Cranes	Combinable	1800	mt	SWL
	Situated on starboard side	2 x 900	mt	SWL
	Fitted with trolley			
	Trolley	37.5	mt	SWL
Main engine	Wärtsilä 8L46C	8775	kW	
	Bowthruster	1000	kW	
	Speed	17	kn	
Container capacity		1237	TEU	

NEWBUILDING HAPPY S-TYPE

Happy Sky	Amsterdam	The Netherlands	2012
Happy Star	Amsterdam	The Netherlands	2012

These particulars are believed to be correct, but without guarantee, and they must not be used as basis for Charter Parties or contracts without Owners' explicit written authority.